

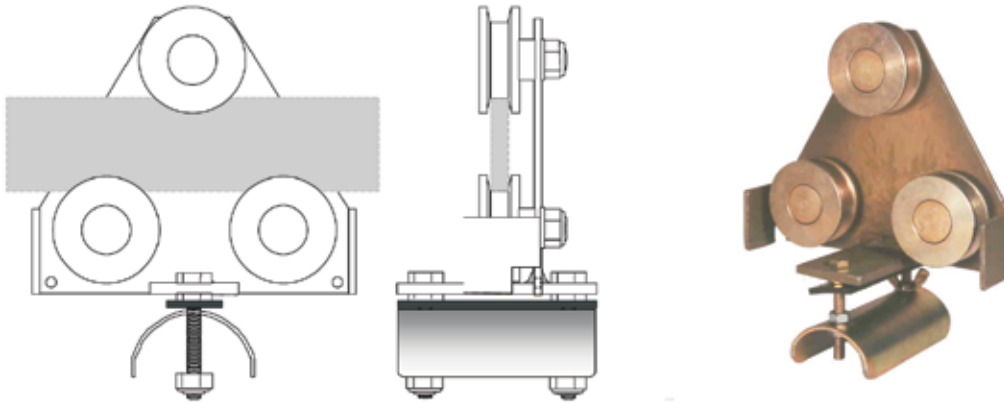

**Cable carrier systems for working environments with heavy dust and dirt build up.
Also ideal for monorail and curved applications as the flat bar rail can be
manipulated on site.**

145



FLAT BAR CARRIER-standard

- 3-FBM-46 Medium duty carrier
- 3-FBH-46 Heavy duty carrier

- 3-FBMC-46 Medium duty master carrier
- 3-FBHC-46 Heavy duty master carrier

- 3-FBMAC-46 Medium duty Anchor clamp
- 3-FBHAC-46 Heavy duty Anchor clamp

FLAT BAR CARRIER-stainless steel

- 3-FBM-4655 Medium duty carrier
- 3-FBH-4655 Heavy duty carrier

- 3-FBMC-4655 Medium duty master carrier
- 3-FBHC-4655 Heavy duty master carrier

- 3-FBMAC-4655 Medium duty Anchor clamp
- 3-FBHAC-4655 Heavy duty Anchor clamp

Bar and hanger system

1. 40 x 6 Flat bar – 6 meter lengths with hole pitched 1,5 plus joint holes
2. Joint plates with fittings
3. Hanger sets with fittings
4. Offset spacer for bar
5. Leader chain

Dome sizes

- Type FBM – Ø50 x 70 cable seat dome
- FBH – Ø90 x 120 cable seat dome

Options on application

1. Sealed wheels with felt ring for fine dust working area
2. Other flat bar sizes available on application
3. Stainless steel bearings on application

Note - For support brackets, see page 29.

4. *When designing a festoon system, the ambush area/parking area must be taken into account.*
5. *Min bending radius = 1000mm*
6. *Support bracket spacing every 0,5 m for curves.*