

Eyebolts

metric coarse thread

- **Material** : carbon steel, C15
- **Safety factor** : MBL equals 4 x WLL
- **Standard** : generally to DIN 580
- **Finish** : self colour
electro-galvanised
- **Certification** : this product is supplied with a works certificate as standard

working load limit	diameter thread	diameter base	diameter eye outside	diameter eye inside	length	thickness base	height	weight per 100 pcs
tonnes	a mm	b mm	c mm	d mm	e mm	f mm	g mm	kg
0.07	6	20	36	20	13	6	36	6.0 *
0.14	8	20	36	20	13	6	36	6.0
0.23	10	25	45	25	17	8	45	10.3
0.34	12	30	54	30	20.5	10	53	17.7
0.49	14	35	63	35	27	12	60	27.7 *
0.7	16	35	63	35	27	12	62	28.0
0.9	18	40	72	40	30	14	71	40.5 *
1.2	20	40	72	40	30	14	71	42.4
1.5	22	45	81	45	35	14	80	67.3 *
1.8	24	50	90	50	36	18	90	83.4
2.5	27	50	90	50	36	18	90	122.0 *
3.6	30	65	108	60	45	22	109	166.0
4.3	33	65	108	60	45	22	110	216.0 *
5.1	36	75	126	70	54	26	128	265.0
6.1	39	75	126	70	54	26	130	334.0 *
7.0	42	85	144	80	63	30	147	403.0
8.0	45	85	144	80	63	30	150	521.0 *
8.6	48	100	166	90	68	35	168	632.0
11.5	56	110	184	100	78	38	187	880.0
16.0	64	120	206	110	90	42	208	1240.0

sizes marked * are additional and proportional to the specification

Eyenuits

metric coarse thread

- **Material** : carbon steel, C15
- **Safety factor** : MBL equals 4 x WLL
- **Standard** : generally to DIN 582
- **Finish** : self colour
electro-galvanised
- **Certification** : this product is supplied with a works certificate as standard

working load limit	diameter thread	diameter base	diameter eye outside	diameter eye inside	thickness base	height	weight per 100 pcs
tonnes	a mm	b mm	c mm	d mm	e mm	f mm	kg
0.07	6	20	36	20	8.5	36	5.2 *
0.14	8	20	36	20	8.5	36	5.2
0.23	10	25	45	25	10	45	9.4
0.34	12	30	54	30	11	53	16.0
0.49	14	35	63	35	13	60	22.0 *
0.7	16	35	63	35	13	62	24.0
1.2	20	40	72	40	16	71	35.2
1.5	22	45	81	45	18	80	58.6 *
1.8	24	50	90	50	20	90	70.6
2.5	27	50	90	50	20	90	102.0 *
3.6	30	65	108	60	25	109	132.0
4.3	33	65	108	60	25	110	170.0 *
5.1	36	75	126	70	30	128	208.0
6.1	39	75	126	70	30	130	260.0 *
7.0	42	85	144	80	35	147	311.0
8.0	45	85	144	80	35	150	407.0 *
8.6	48	100	166	90	40	168	502.0

sizes marked * are additional and proportional to the specification

For higher working load, load limits for special applications
Go to page 145 - 163

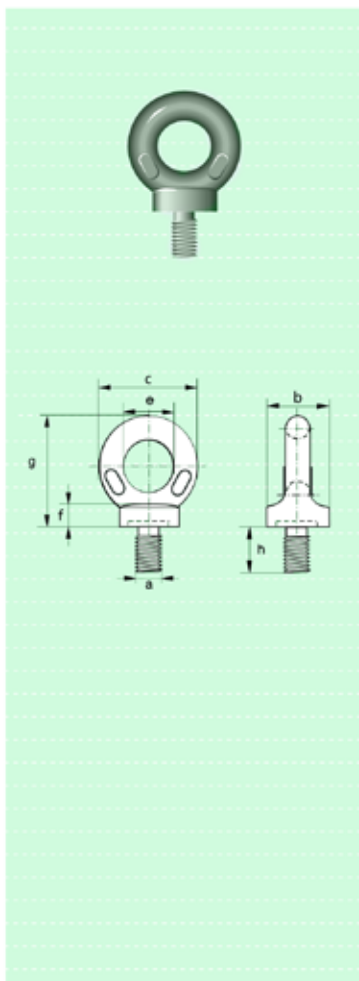

Collared Eyebolts - Quality Range

metric coarse thread

- **Material** : BS970-080A27 hardened and tempered
- **Safety Factor** : MBL equals 5 x SWL
- **Standard** : B.S. 4278 - table 1 - 1984
- **Finish** : self colour, electro-galvanised upon request
- **Certificates** : this product is supplied with a test certificate as standard

safe working load tonnes	diameter thread	diameter base	diameter eye outside	diameter eye inside	thickness collar	height	thread length	weight each
	a mm	b mm	c mm	e mm	f mm	g mm	h mm	kg
0.10	6	22	33	15	7	36	18	0.06 *
0.15	8	22	33	15	7	36	18	0.06 *
0.25	10	22	33	15	7	36	18	0.06 *
0.40	12	22	33	15	7	36	18	0.06 *
0.50	14	29	44	20	10	48	23	0.15 *
0.80	16	29	44	20	10	48	23	0.15 *
1.00	18	36	52	24	12	58	28	0.27 *
1.60	20	40	59	27	14	65	32	0.38 *
1.60	22	45	64	30	14	73	35	0.54 *
2.50	24	52	77	35	17	84	40	0.85 *
2.50	27	58	85	39	20	94	46	1.13 *
4.00	30	65	96	44	22	106	51	1.62 *
4.00	33	72	106	48	24	117	56	2.37 *
6.30	36	81	118	54	27	131	63	3.12 *
6.30	39	86	123	57	29	137	67	3.81 *
8.00	42	101	148	68	34	164	79	6.27 *
8.00	45	101	148	68	34	164	79	6.45 *
10.00	48	101	148	68	34	164	79	6.51 *
12.50	52	115	168	76	38	186	89	9.58 *
16.00	56	128	188	86	43	208	100	12.99 *
20.00	64	144	212	96	48	234	112	18.20 *

sizes marked * are additional and proportional to the specification

For higher working load, load limits for special applications
Go to page 145 - 163

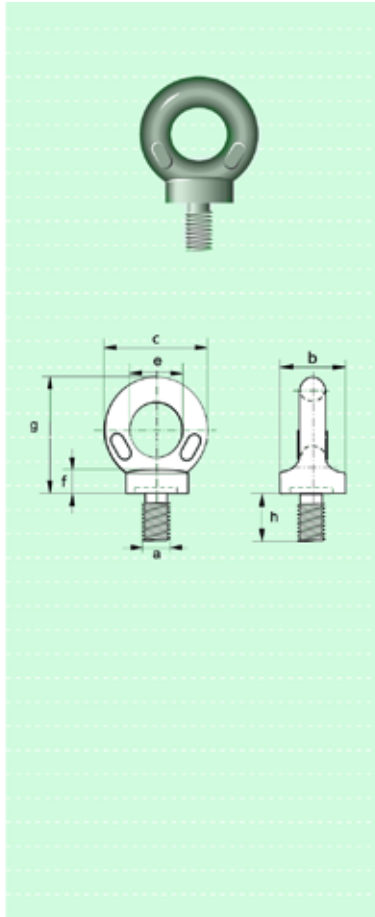

Collared Eyebolts - Quality Range

BSW thread

- Material : BS970-080A27 hardened and tempered
- Safety Factor : MBL equals 5 x SWL
- Standard : B.S. 4278 - table 4 - 1984
- Finish : self colour, electro-galvanised upon request
- Certificates : this product is supplied with a works certificate as standard

safe working load	diameter thread	diameter base	diameter eye outside	diameter eye inside	thickness collar	height	thread length	weight each
tonnes	a inch	b mm	c mm	e mm	f mm	g mm	h mm	kg
0.10	1/4	22	33	15	7	36	18	0.06 *
0.15	5/16	22	33	15	7	36	18	0.06 *
0.25	3/8	22	33	15	7	36	18	0.06
0.50	1/2	29	44	20	10	48	23	0.15
0.90	5/8	36	52	24	12	58	28	0.27
1.40	3/4	45	66	30	14	73	35	0.54
2.00	7/8	52	77	35	17	84	40	0.85
2.75	1	58	85	39	20	94	46	1.13
3.50	1 1/8	65	96	44	22	106	51	1.62
4.50	1 1/4	72	106	48	24	117	56	2.37
6.50	1 1/2	81	118	54	27	131	63	3.12 *
9.00	1 3/4	101	148	68	34	164	79	6.27
12.00	2	115	168	76	38	186	89	9.58

sizes marked * are additional and proportional to the specification

For higher working load, load limits for special applications
Go to page 145 - 163

Safety Instructions - Eyebolts for BSW and metric coarse thread

- **Standard** : B.S. 4278 Tables 1 and 4 - 1984
- **Note** : maximum recommended working loads for British standard eyebolts imperial and metric coarse threads when used in pairs for inclined working conditions

SWL for a single eyebolt in vertical lift	angle of lift between sling legs		
	0° > 30°	30° > 60°	60° > 90°
tonnes	tonnes	tonnes	tonnes
0.25	0.32	0.20	0.13
0.40	0.50	0.32	0.20
0.50	0.63	0.40	0.25
0.80	1.00	0.64	0.40
0.90	1.13	0.72	0.45
1.00	1.30	0.80	0.50
1.25	1.60	1.00	0.63
1.40	1.76	1.12	0.70
1.60	2.00	1.25	0.80
2.00	2.50	1.60	1.00
2.50	3.20	2.00	1.25
2.75	3.47	2.20	1.38
3.20	4.00	2.50	1.60
3.50	4.41	2.80	1.75
4.00	5.00	3.20	2.00
4.50	5.67	3.60	2.25
5.00	6.30	4.00	2.50
6.30	8.00	5.00	3.20
8.00	10.00	6.30	4.00
9.00	11.34	7.20	4.50
10.00	12.50	8.00	5.00
12.00	15.12	9.60	6.00
12.50	16.00	10.00	6.30
15.00	18.90	12.00	7.50
16.00	20.00	12.50	8.00
20.00	25.20	16.00	10.00

Safety Instructions - Eyebolts and Eyenuts metric coarse thread

- **Standard** : Eyebolt DIN 580 - Eyenut DIN 582
- **Note** : maximum recommended working loads when used in pairs for inclined working conditions

SWL for a single eyebolt in vertical lift	angle of lift between sling legs	
	0°	45°
kg	kg	kg
140	140	95
230	230	170
340	340	240
700	700	500
1200	1200	830
1800	1800	1270
3600	3600	2600
5100	5100	3700
7000	7000	5000
8600	8600	6100
11500	11500	8300
16000	16000	11000

For higher working load, load limits for special applications
Go to page 145 - 163